

STEP 1

MEASURE DOOR THICKNESS.

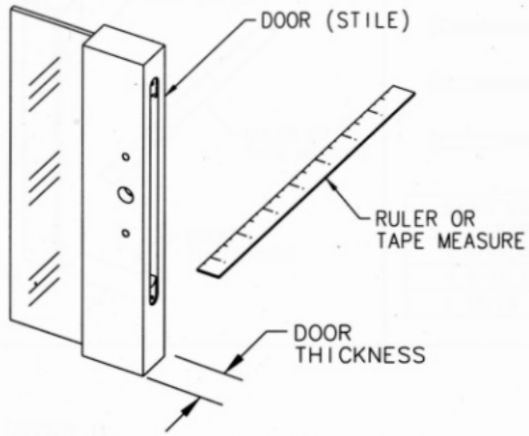

STEP 2

DETERMINE THE PROPER LENGTH OF MOUNTING SCREWS.

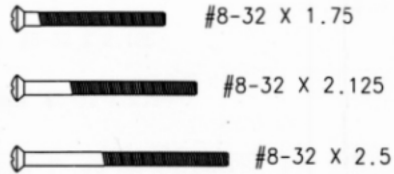

DOOR THICKNESS RANGE	#8-32 PHILLIPS SCREW LENGTH
1 3/16 TO 1 9/16	1.750
1 9/16 TO 1 15/16	2.125
1 15/16 TO 2 5/16	2.500

TRUTH HARDWARE
 Truth Hardware
 an FKI Industries company
 700 West Bridge Street
 Owatonna, MN 55060
 Telephone 507-451-5620

INSTALLATION INSTRUCTIONS

HANDLES, KEEPERS AND OTHER COMPONENTS MAY NOT BE AN EXACT MATCH WITH WHAT YOU ARE INSTALLING BUT THE INSTALLATION PROCEDURE IS BASICALLY THE SAME.

STEP 5

BREAK OFF TAIL ENDS WITH PLIERS

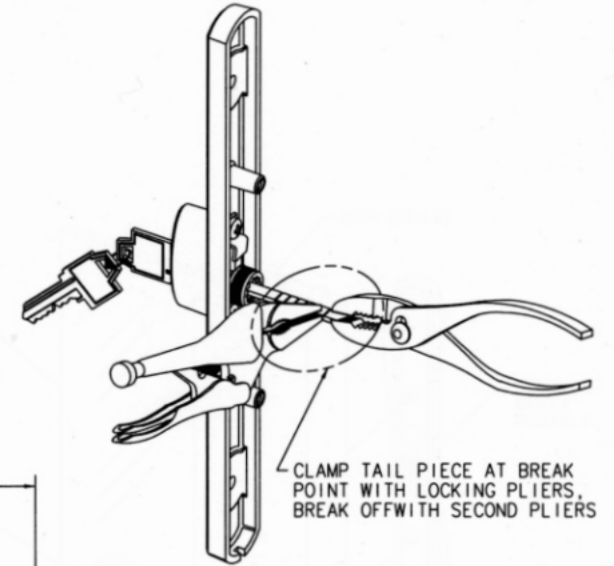

STEP 3

LOCK CYLINDER / ESCUTCHEON ASSEMBLY

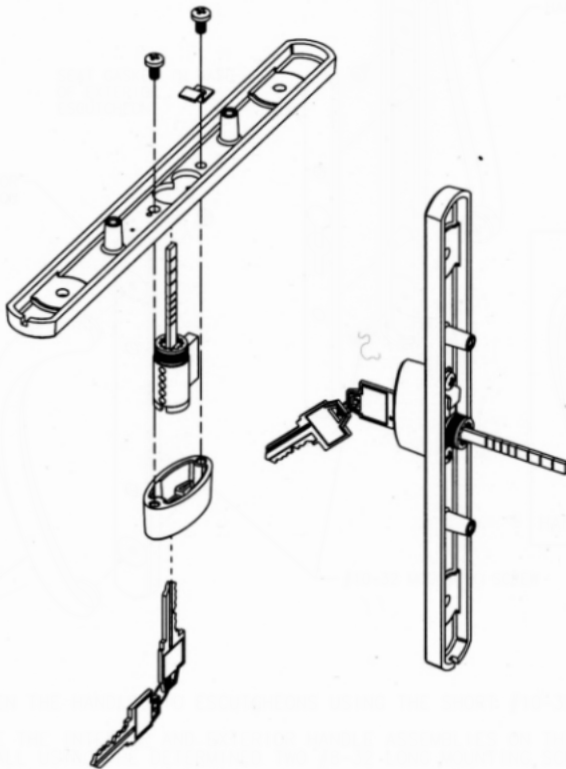

STEP 4

SIZE TAIL PIECES TO SUIT DOOR THICKNESS

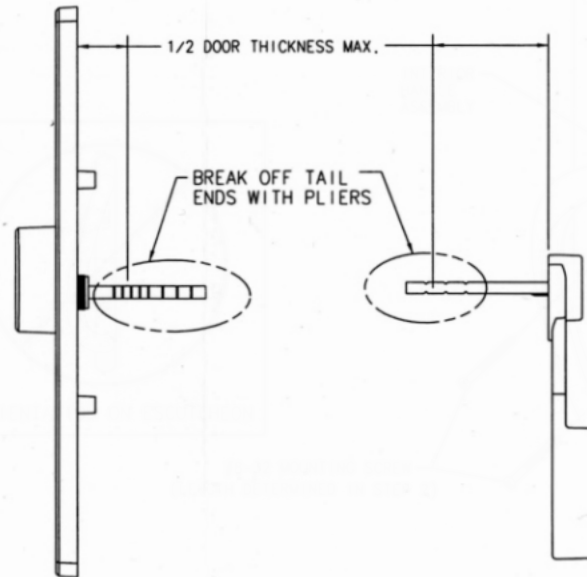

DETERMINING TAIL PIECE BY FINDING BREAK MARK CLOSEST TO 1/2 DOOR THICKNESS MAX.

Handle Sets with Interior Latch / Exterior Lock

STEP 6

HANDLE TO ESCUTCHEON ASSEMBLY

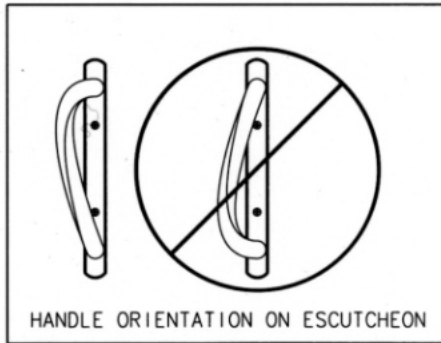
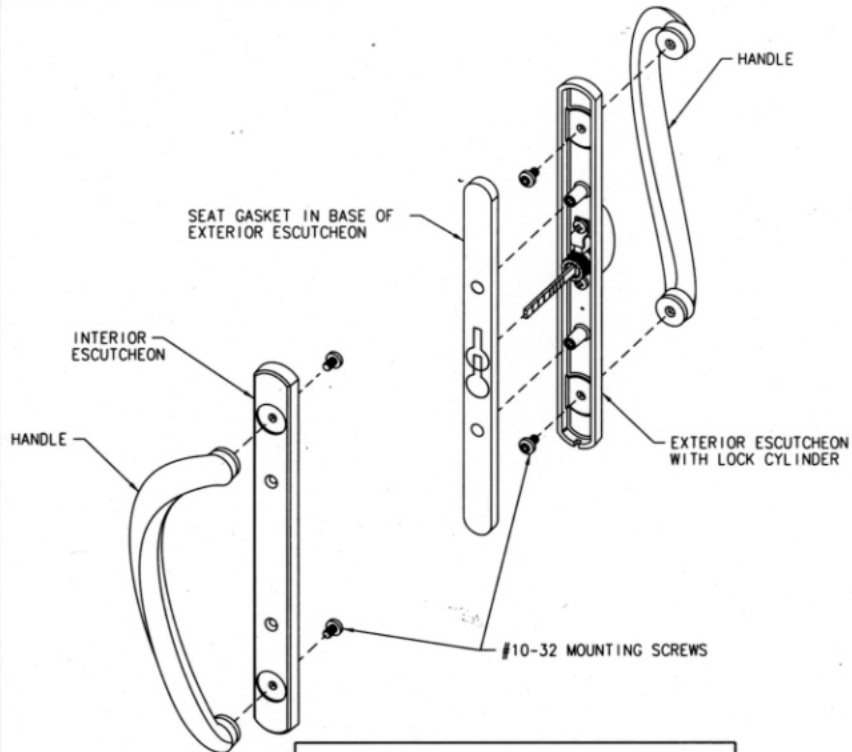

NOTE:

1. FASTEN THE HANDLES TO ESCUTCHEONS USING THE SHORT #10-32 MOUNTING SCREWS AS INDICATED AND TIGHTEN AS REQUIRED.
2. INSTALL MORTISE LOCK AND INSERT THUMB LEVER WITH TUNG EXTENDING INTO DRIVE HUB OF THE MORTISE.
3. PLACE THE EXTERIOR HANDLE ASSEMBLY WITH CYLINDER TAIL EXTENDING THROUGH MORTISE LOCK DRIVE HUB.
4. PLACE INTERIOR HANDLE ASSEMBLY OVER THE THUMB LEVER AND FASTEN TO EXTERIOR HANDLE ASSEMBLY USING THE DETERMINED TWO #8-32 LONG MOUNTING SCREWS AND TIGHTEN AS REQUIRED.
5. BE SURE TO MOUNT HANDLE ASSEMBLIES ON DOOR WITH HANDGRIP TOWARD GLASS.
6. USE PROPER TOOLS AND PROTECTIVE EYEWEAR DURING INSTALLATION.



Truth Hardware
an FKI Industries company
700 West Bridge Street
Owatonna, MN 55060
Telephone 507-451-5620

INSTALLATION INSTRUCTIONS

HANDLES, KEEPERS AND OTHER COMPONENTS MAY NOT BE AN EXACT MATCH WITH WHAT YOU ARE INSTALLING BUT THE INSTALLATION PROCEDURE IS BASICALLY THE SAME.

STEP 7

INSTALL HANDLE SET TO DOOR

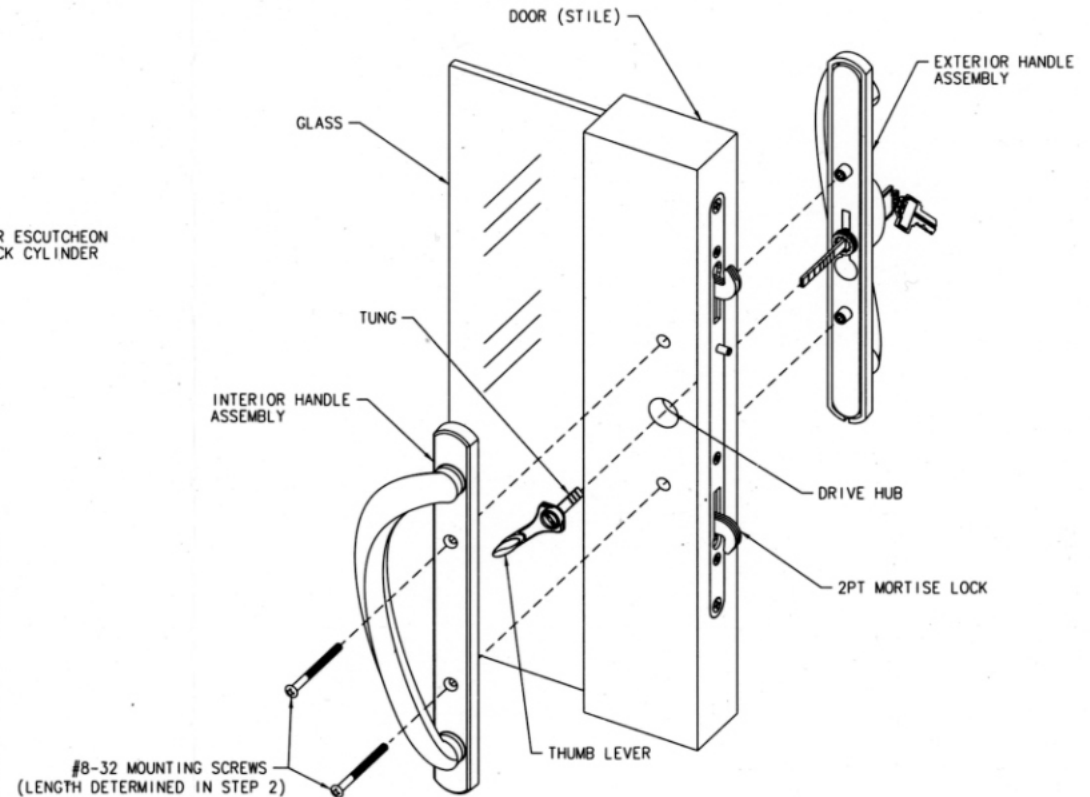

Handle Sets without Latch / Lock

STEP 1

MEASURE DOOR THICKNESS.

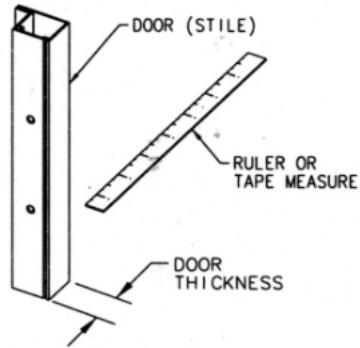

STEP 2

DETERMINE THE PROPER LENGTH OF MOUNTING SCREWS.

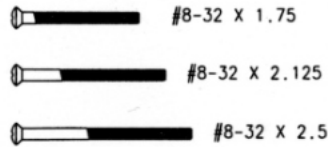

DOOR THICKNESS RANGE	#8-32 PHILLIPS SCREW LENGTH
1 3/16 TO 1 9/16	1.750
1 9/16 TO 1 15/16	2.125
1 15/16 TO 2 5/16	2.500



Truth Hardware
an FKI Industries company
700 West Bridge Street
Owatonna, MN 55060
Telephone 507-451-5620

INSTALLATION INSTRUCTIONS

HANDLES, KEEPERS AND OTHER COMPONENTS MAY NOT BE AN EXACT MATCH WITH WHAT YOU ARE INSTALLING BUT THE INSTALLATION PROCEDURE IS BASICALLY THE SAME.

STEP 3

HANDLE TO ESCUTCHEON ASSEMBLY.

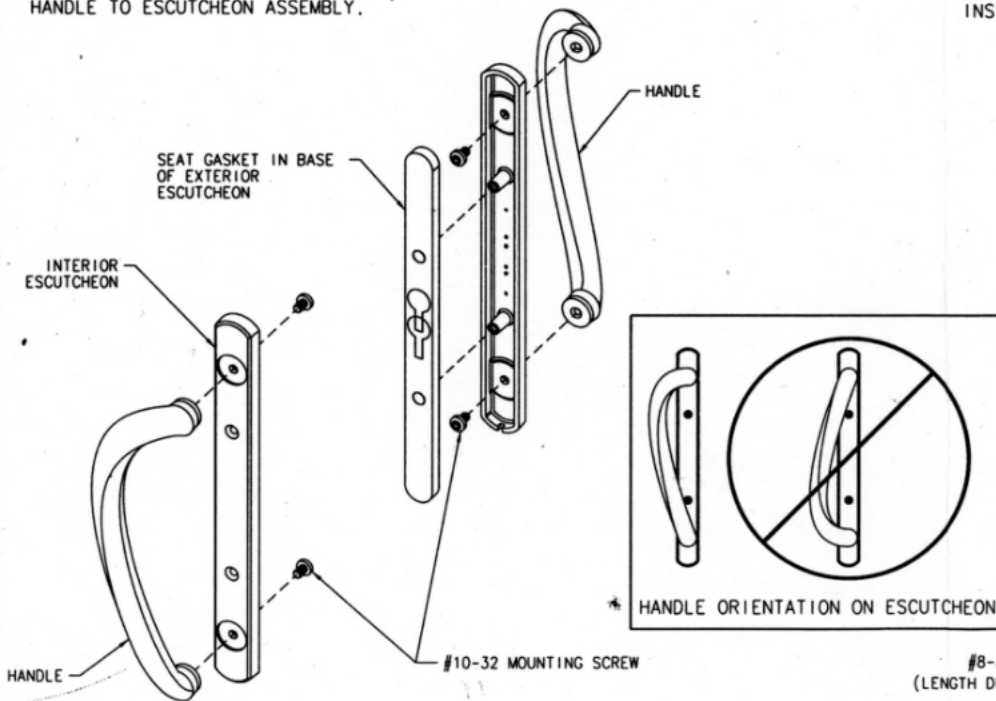

STEP 4

INSTALL HANDLE SET TO DOOR.

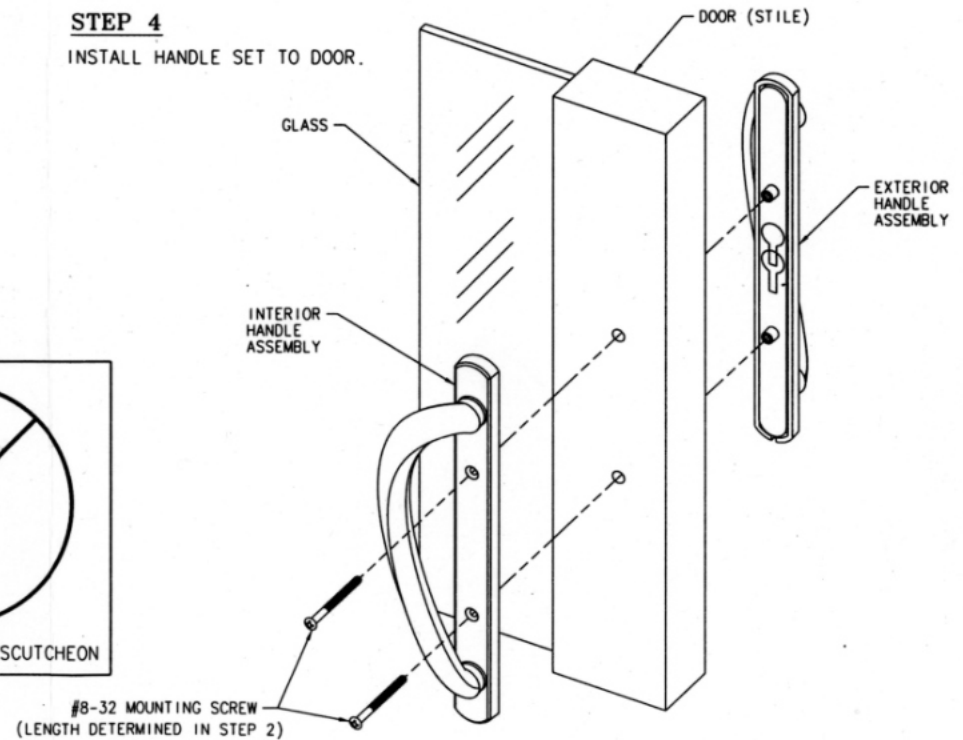

1. FASTEN THE HANDLES TO ESCUTCHEONS USING THE SHORT #10-32 MOUNTING SCREWS AS INDICATED AND TIGHTEN AS REQUIRED.
2. PLACE THE INTERIOR AND EXTERIOR HANDLE ASSEMBLIES ON THE DOOR WITH THE HANDGRIP TOWARD THE GLASS, INSTALL USING THE DETERMINED TWO #8-32 LONG MOUNTING SCREWS AND TIGHTEN AS REQUIRED.
3. USE PROPER TOOLS AND PROTECTIVE EYEWEAR DURING INSTALLATION.