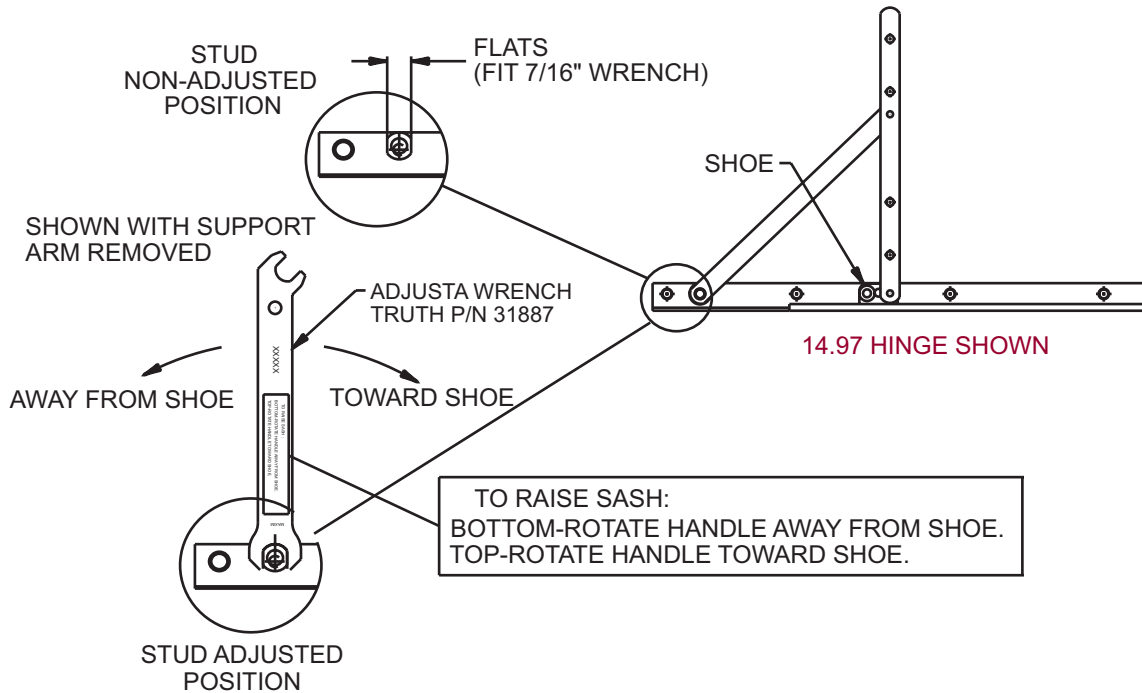

FIG. 3 INSTRUCTIONS FOR SASH ADJUSTMENT 14.12 AND 14.97 HINGES



#### INSTRUCTIONS FOR SASH ADJUSTMENT

1. THE AMOUNT OF SASH DRAG THAT THIS HINGE WILL CORRECT FOR, IS DEPENDENT ON THE RATIO OF THE SASH WIDTH VS. SASH HEIGHT. TO CALCULATE THE AMOUNT OF SASH DRAG ADJUSTMENT FOR ANY GIVEN WINDOW SIZE, TAKE THE RATIO OF THE WIDTH TO HEIGHT MULTIPLIED BY 1/16.

EXAMPLE: SASH SIZE EQUALS 24" X 36", WIDTH TO HEIGHT RATIO IS .667.  
TOTAL ADJUSTMENT IS  $.667 \times 1/16" = .042"$  (APPROX. 3/64")

2. TO ADJUST THE CASEMENT SASH, FIRST FULLY OPEN THE WINDOW. NEXT, SLIP THE ADJUSTMENT WRENCH (TRUTH PART NO. 31887) ONTO THE BASE OF THE STUD, FOUND BETWEEN THE SUPPORT ARM AND THE TRACK OF THE LOWER HINGE. SWINGING THE WRENCH TOWARD THE LOCK SIDE OF THE WINDOW WILL DECREASE THE AMOUNT OF SASH DRAG. THE MAXIMUM SASH DRAG ADJUSTMENT IS REACHED WHEN THE STUD FLATS ARE 45° TO THE TRACK.

NOTE: DO NOT TURN PAST 45° OR ARM WILL BIND ON TRACK.

3. FOR SEVERE SASH DRAG, A SIMILAR PROCEDURE CAN BE USED ON THE UPPER HINGE. UPPER HINGE ADJUSTMENT IS MADE BY SWINGING THE WRENCH AWAY FROM THE LOCK SIDE OF THE WINDOW. MAXIMUM ADJUSTMENT IS OBTAINED WHEN THE STUD FLATS ARE 45° TO THE TRACK.

NOTE: MAXIMUM ADJUSTMENT MAY CAUSE BINDING AS THE WINDOW IS CLOSED. PLEASE USE CAUTION.

4. STUD MAY BE ADJUSTED WITH 7/16" WRENCH IF SUPPORT ARM IS REMOVED BEFORE ADJUSTMENT.